

## 4-Lane DisplayPort™ Rev 1.1a Compliant Switch with Triple Control Logic for Fast Switching

### Features

- 4-lane, 1:2 mux/demux that will support 2.7Gbps or 1.62Gbps DP rev 1.1a signals
- 1-channel 1:2 mux/demux for DP\_HPDP signal
- 1-differential channel 1:2 mux/demux for DP\_Aux signal
- Insertion Loss for high speed channels @ 2.7 Gbps: -1.5dB
- -3dB Bandwidth for high speed channels of 3.25 Ghz
- Low Bit-to-Bit Skew , 7ps max (between '+' and '-' bits)
- Low Crosstalk for high speed channels: -33dB@2.7 Gbps
- Low Off Isolation for high speed channels: -26dB@2.7 Gbps
- V<sub>DD</sub> Operating Range: 3.3V ±10%
- ESD Tolerance: +/-8kV contact on Ports A and B per IEC61000-4-2 Specification
- Low channel-to-channel skew, 35ps max
- Packaging (Pb-free & Green):
  - -56 TQFN (ZFE)
  - -42 TQFN (ZHE)

### Description

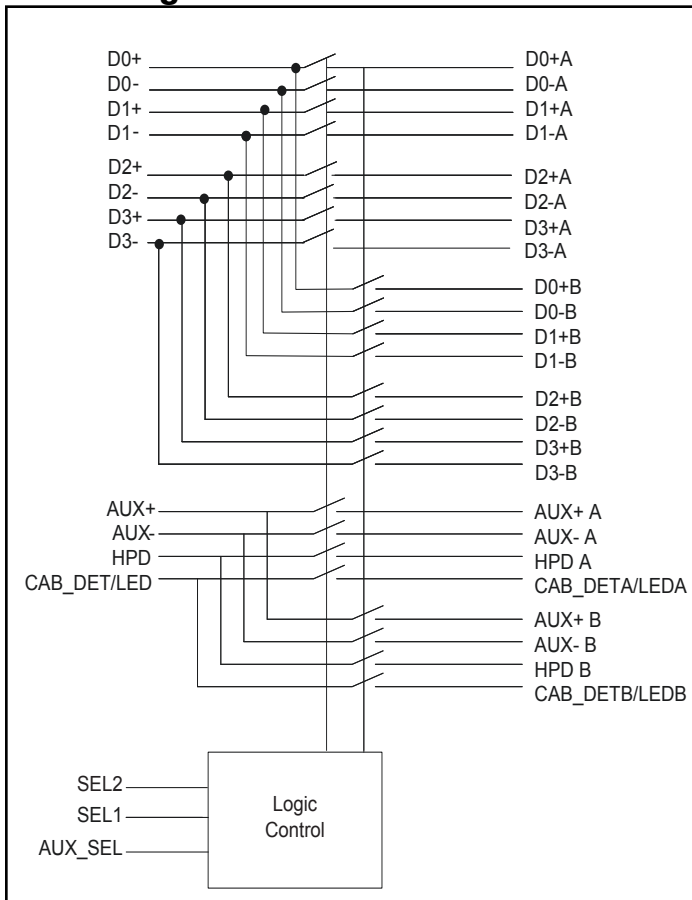
Pericom Semiconductor's PI3VDP612-A mux/demux is targeted for next generation digital video signals. This device can be used to connect a DisplayPort™ Source to two Independent DisplayPort Sinks or to connect two DisplayPort sources to a single DP display.

The newly released DisplayPort spec requires a data rate of 2.7 Gbps with AC coupled I/Os. Pericom's solution has been specifically designed around this standard and will support such signals.

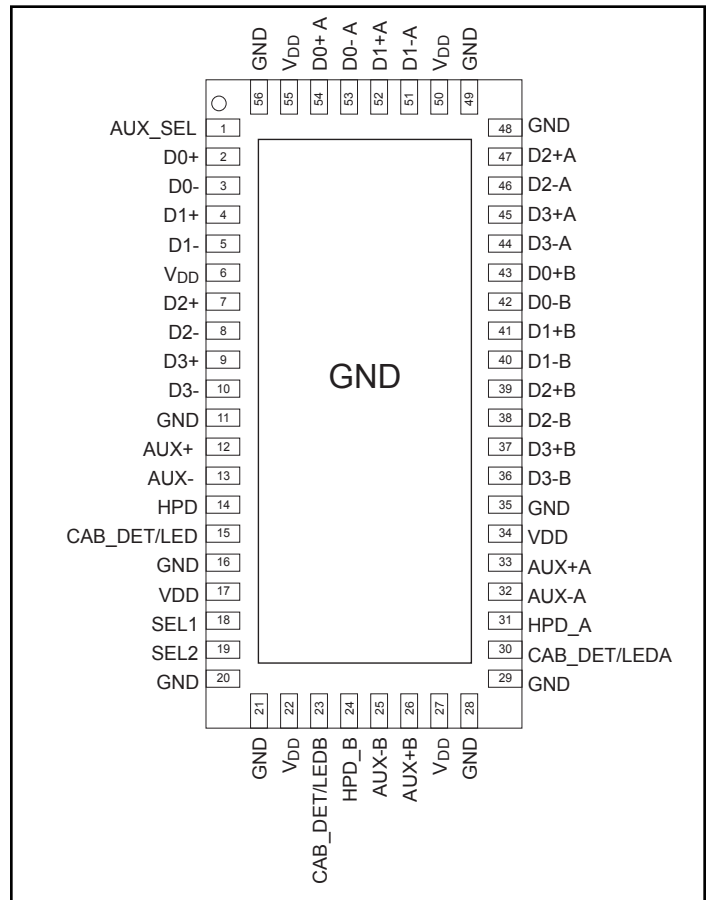
### Application

Routing of DisplayPort signals with low signal attenuation between source and sink.

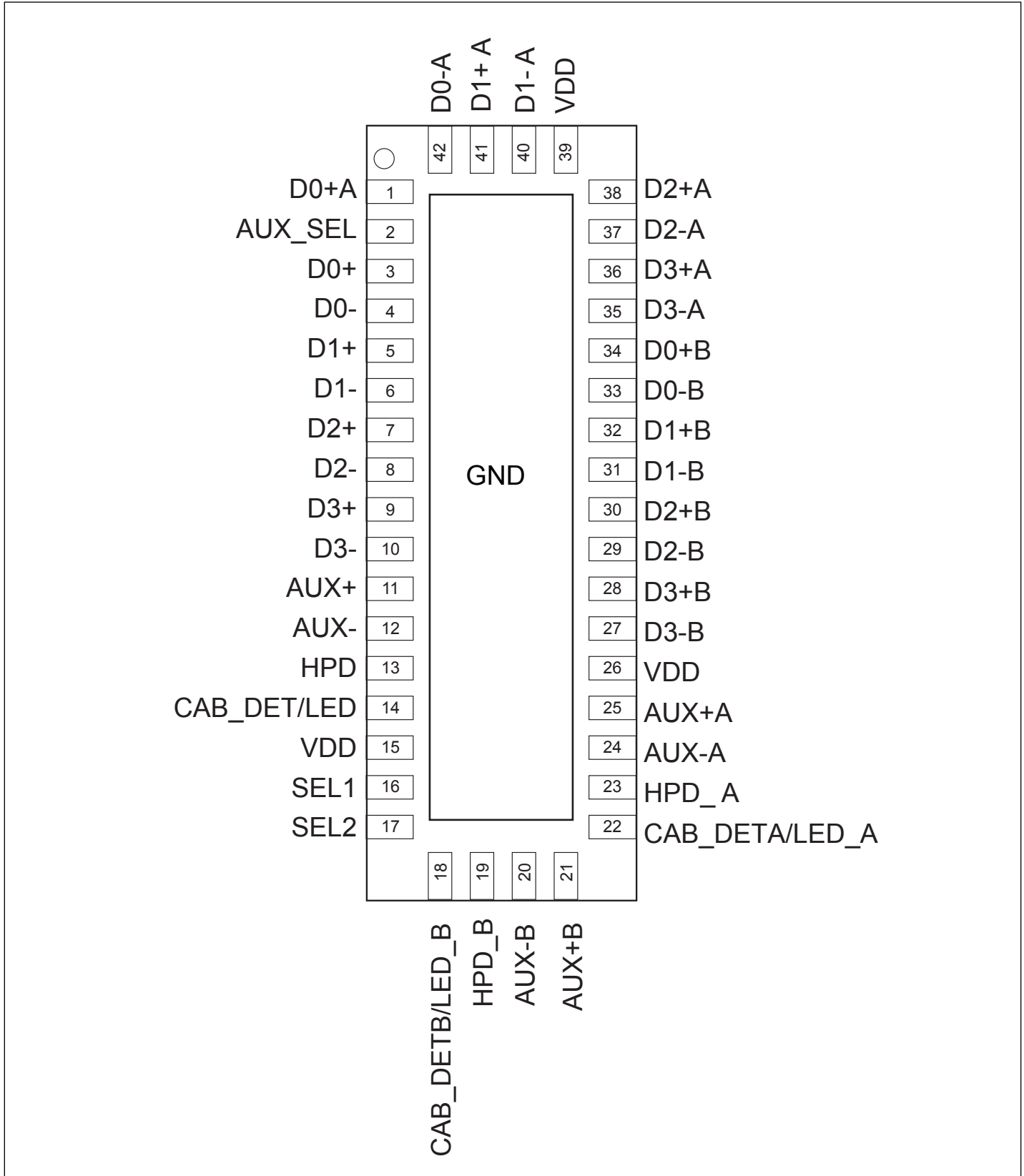
### Block Diagram



### Pin Description - 56-Pin



**Pin Description - 42-Pin**



## Pin Description

42-Package Pin #	56-Package Pin #	Pin Name	Signal Type	Description	ESD
2	1	AUX_SEL	Input	Logic control for AUX signals: if LOW then AUX from COM port will connect to AUX from port A. If HIGH, then AUX from COM port will connect to AUX from port B.	
3	2	D0+	I/O	Positive Lane0 signal for common port	+/-7kV
4	3	D0-	I/O	Negative Lane0 signal for common port	+/-7kV
5	4	D1+	I/O	Positive Lane1 signal for common port	+/-7kV
6	5	D1-	I/O	Negative Lane1 signal for common port	+/-7kV
15, 26, 39	6, 17, 22, 27, 34, 50, 55	V <sub>DD</sub>	Power	3.3V Power Supply	
7	7	D2+	I/O	Positive Lane2 signal for common port	+/-7kV
8	8	D2-	I/O	Negative Lane2 signal for common port	+/-7kV
9	9	D3+	I/O	Positive Lane3 signal for common port	+/-7kV
10	10	D3-	I/O	Negative Lane3 signal for common port	+/-7kV
*GND plate	11, 16, 20, 21, 28, 29, 35, 48, 49, 56	GND	Ground	Ground	
11	12	AUX+	I/O	Positive AUX signal for common port	+/-8kV
12	13	AUX-	I/O	Negative AUX signal for common port	+/-8kV
13	14	HPD	I/O	HPD for common port	+/-8kV
14	15	CAB_DET/LED	I/O	Common port pin for cable detect signal or LED common port	+/-8kV
16	18	SEL1	Input	Port Selection Control. If LOW, then port A is active. If HIGH, then port B is active	
17	19	SEL2	Input	Port Selection Control for HPD path and CAB_DET/LED path only: If LOW, then port A is active. If HIGH, then port B is active.	
	20	GND	Power	Ground	
	21	GND	Power	Ground	
	22	V <sub>DD</sub>	Power	3.3V Power Supply	
18	23	CAB_DET <sub>B</sub> /LED <sub>B</sub>	I/O	Port B pin13 from dual mode DP connector or LED from port B	+/-8kV
19	24	HPD <sub>B</sub>	I/O	HPD for port B	+/-8kV
20	25	AUX-B	I/O	Negative AUX signal for Port B	+/-8kV
21	26	AUX+B	I/O	Positive AUX signal for Port B	+/-8kV

(Continued)

### Pin Description

42-Package Pin #	56-Package Pin #	Pin Name	Signal Type	Description	ESD
22	30	CAB_DETA/ LEDA	I/O	Port A cable detect from dual mode DP connector or LED from port A	+/-8kV
23	31	HPD_A	I/O	HPD for port A	+/-8kV
24	32	AUX-A	I/O	Negative AUX signal for Port A	+/-8kV
25	33	AUX+A	I/O	Positive AUX signal for Port A	+/-8kV
27	36	D3-B	I/O	Negative Lane3 signal for Port B	+/-8kV
28	37	D3+B	I/O	Positive Lane3 signal for Port B	+/-8kV
29	38	D2-B	I/O	Negative Lane2 signal for Port B	+/-8kV
30	39	D2+B	I/O	Positive Lane2 signal for Port B	+/-8kV
31	40	D1-B	I/O	Negative Lane1 signal for Port B	+/-8kV
32	41	D1+B	I/O	Positive Lane1 signal for Port B	+/-8kV
33	42	D0-B	I/O	Negative Lane0 signal for Port B	+/-8kV
34	43	D0+B	I/O	Positive Lane0 signal for Port B	+/-8kV
35	44	D3-A	I/O	Negative Lane3 signal for Port A	+/-8kV
36	45	D3+A	I/O	Positive Lane3 signal for Port A	+/-8kV
37	46	D2-A	I/O	Negative Lane2 signal for Port A	+/-8kV
38	47	D2+A	I/O	Positive Lane2 signal for Port A	+/-8kV
40	51	D1-A	I/O	Negative Lane1 signal for Port A	+/-8kV
41	52	D1+A	I/O	Positive Lane1 signal for Port A	+/-8kV
42	53	D0-A	I/O	Negative Lane0 signal for Port A	+/-8kV
1	54	D0+A	I/O	Positive Lane0 signal for Port A	+/-8kV

### Truth Table (SEL control)

Function	SEL 1/SEL2/AUX_SEL
Port A is active	L
Port B is active	H

**Notes:**

SEL1 is only for DP lanes

SEL2 is only for HPD/CAB\_DET signals

AUX\_SEL is only for AUX path

## Maximum Ratings

(Above which useful life may be impaired. For user guidelines, not tested.)

Storage Temperature .....	-65°C to +150°C
Supply Voltage to Ground Potential .....	-0.5V to +3.6V
DC Input Voltage .....	-0.7V to 3.6V
DC Output Current .....	120mA
Power Dissipation .....	0.5W

**Note:** Stresses greater than those listed under MAXIMUM RATINGS may cause permanent damage to the device. This is a stress rating only and functional operation of the device at these or any other conditions above those indicated in the operational sections of this specification is not implied. Exposure to absolute maximum rating conditions for extended periods may affect reliability.

## DC Electrical Characteristics for Switching over Operating Range (T<sub>A</sub> = -40°C to +85°C, V<sub>DD</sub> = 3.3V ±10%)

Parameter	Description	Test Conditions <sup>(1)</sup>	Min	Typ <sup>(1)</sup>	Max	Units
V <sub>IH</sub>	Input HIGH Voltage	Guaranteed HIGH level	1.6			V
V <sub>IL</sub>	Input LOW Voltage	Guaranteed LOW level			0.75	
V <sub>IK</sub>	Clamp Diode Voltage	V <sub>DD</sub> = Max., I <sub>IN</sub> = -18mA		-0.7	-1.2	
I <sub>IH</sub>	Input HIGH Current	V <sub>DD</sub> = Max., V <sub>IN</sub> = V <sub>DD</sub>			±5	µA
I <sub>IL</sub>	Input LOW Current	V <sub>DD</sub> = Max., V <sub>IN</sub> = GND			±5	
I <sub>OFF</sub>	I/O leakage when part is off	V <sub>DD</sub> = 0V, V <sub>INPUT</sub> = 0V to 3.6V			50	
R <sub>ON</sub>	On resistance between input to output	V <sub>DD</sub> = 3.0V, -0.6V < V <sub>INPUT</sub> < 0.6V			7	Ohm
		V <sub>DD</sub> = 3.0V, 1.0V < V <sub>INPUT</sub> < 1.5V			10	Ohm

## Power Supply Characteristics (T<sub>A</sub> = 0°C to +70°C)

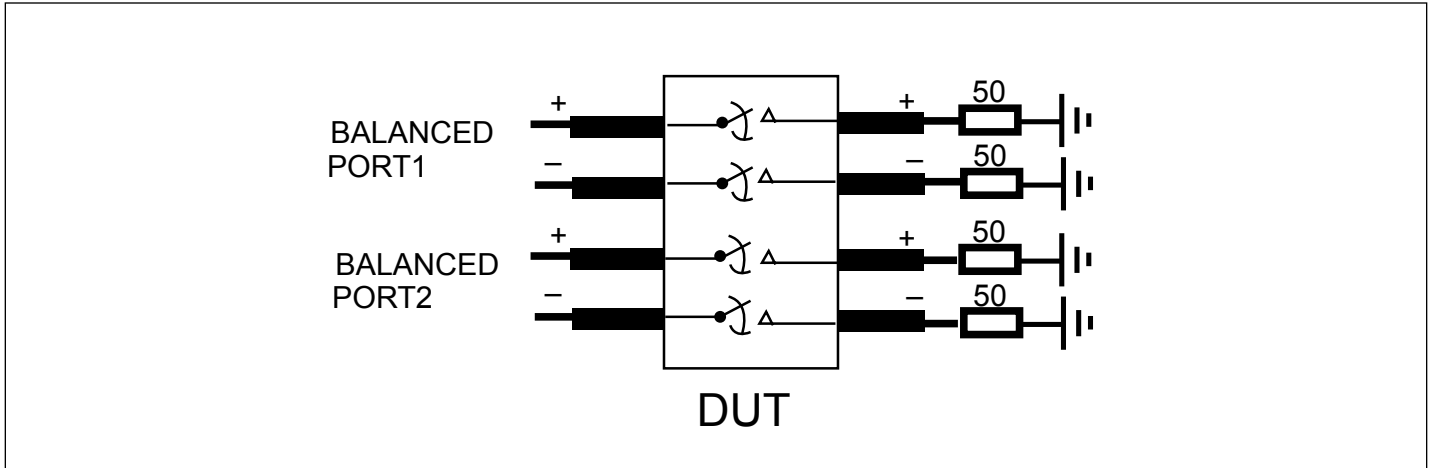
Parameter	Description	Test Conditions <sup>(1)</sup>	Min	Typ <sup>(1)</sup>	Max	Units
I <sub>CC</sub>	Quiescent Power Supply Current	V <sub>DD</sub> = Max., V <sub>IN</sub> = GND or V <sub>DD</sub>			70	µA

## Dynamic Electrical Characteristics over Operating Range (T<sub>A</sub> = -40° to +85°C, V<sub>DD</sub> = 3.3V ±10%, GND=0V)

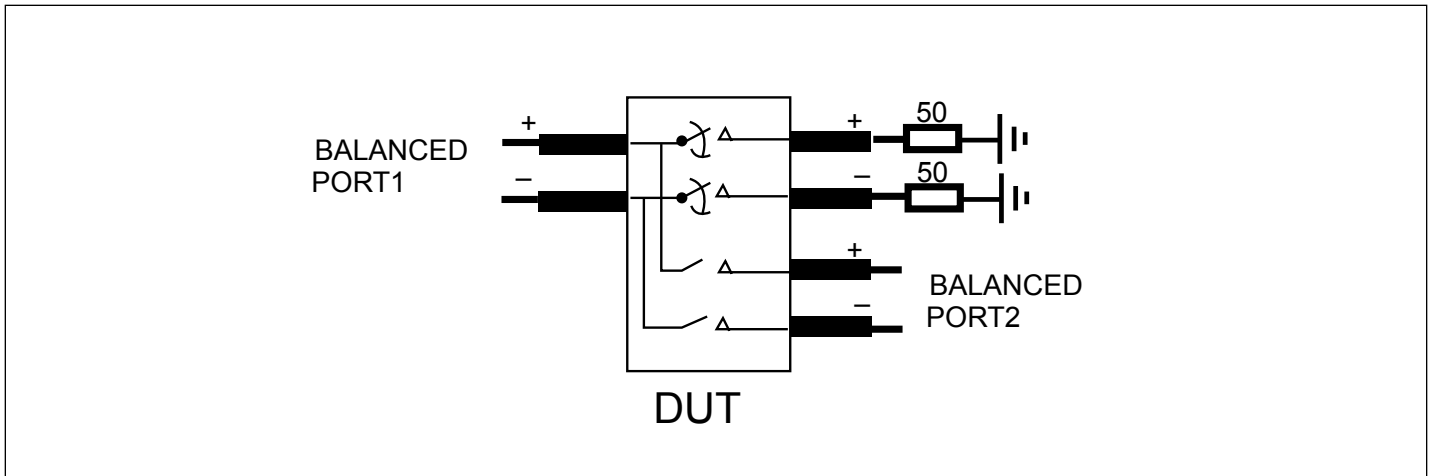
Parameter	Description	Test Conditions	Typ. <sup>(2)</sup>	Units
X <sub>TALK</sub>	Crosstalk on High Speed Channels	See Fig. 1 for Measurement Setup	f = 1.35 GHz	-33dB
			f = 100 MHz	-48dB
O <sub>IRR</sub>	OFF Isolation on High Speed Channels	See Fig. 2 for Measurement Setup,	f = 1.35 GHz	-33dB
			f = 100 MHz	-56dB
I <sub>LOSS</sub>	Differential Insertion Loss on High Speed Channels	@2.7Gbps (see figure 3)	-1.5	dB
BW <sub>Dx±</sub>	Bandwidth -3dB for Main high speed path (Dx±)	See figure 3	3.25	GHz
BW <sub>AUX/HPD</sub>	-3dB BW for AUX and HPD signals	See figure 3	1.5	GHz

**Notes:**

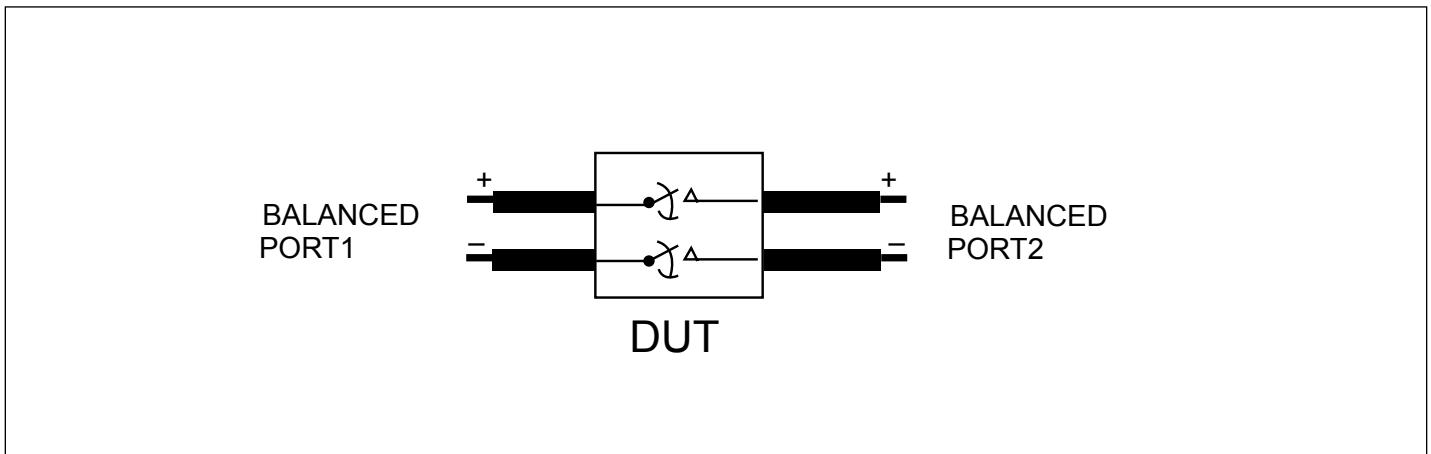
- For Max. or Min. conditions, use appropriate value specified under Electrical Characteristics for the applicable device type.
- Typical values are at V<sub>DD</sub> = 3.3V, T<sub>A</sub> = 25°C ambient and maximum loading.



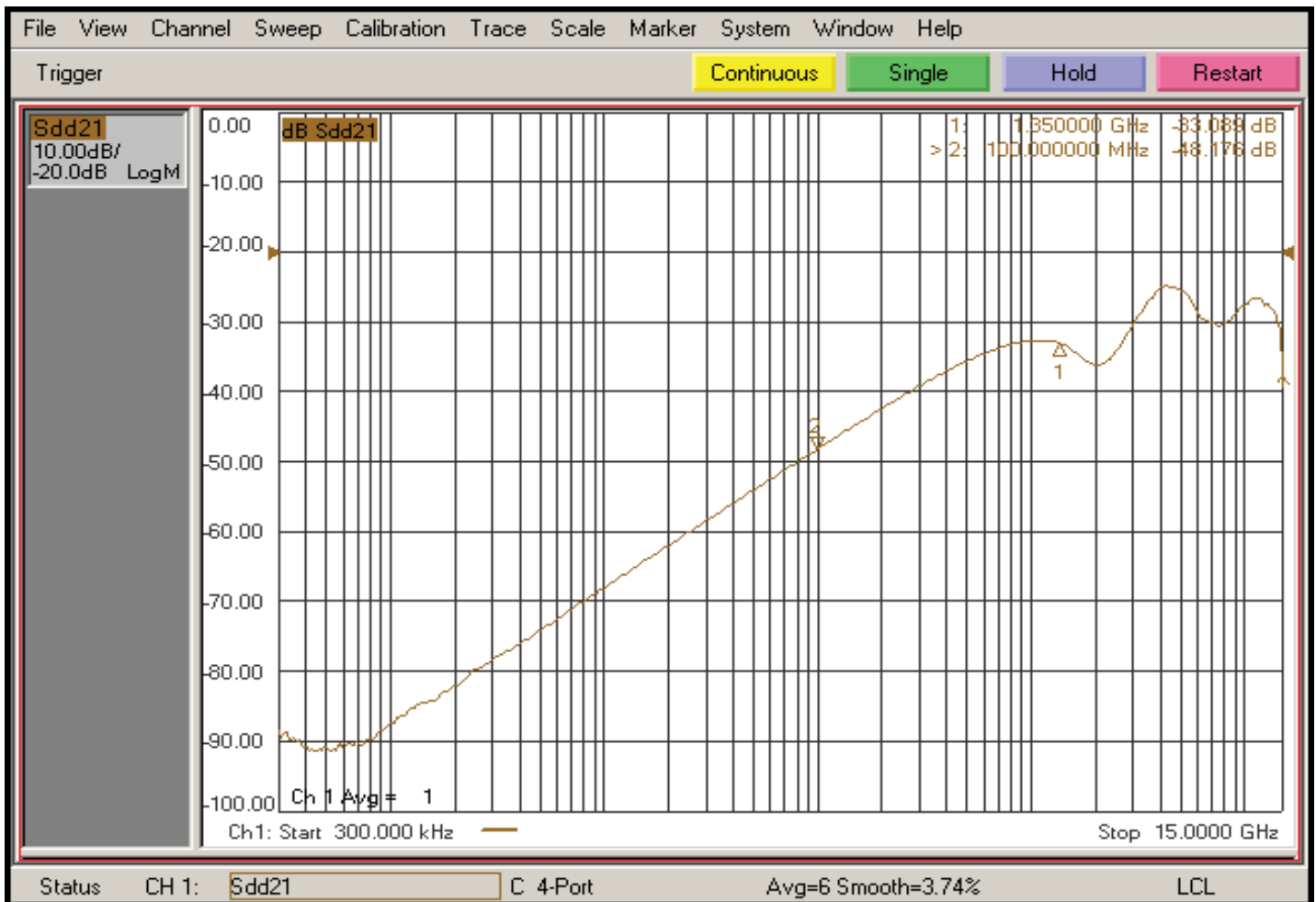
**Fig 1. Crosstalk Setup**



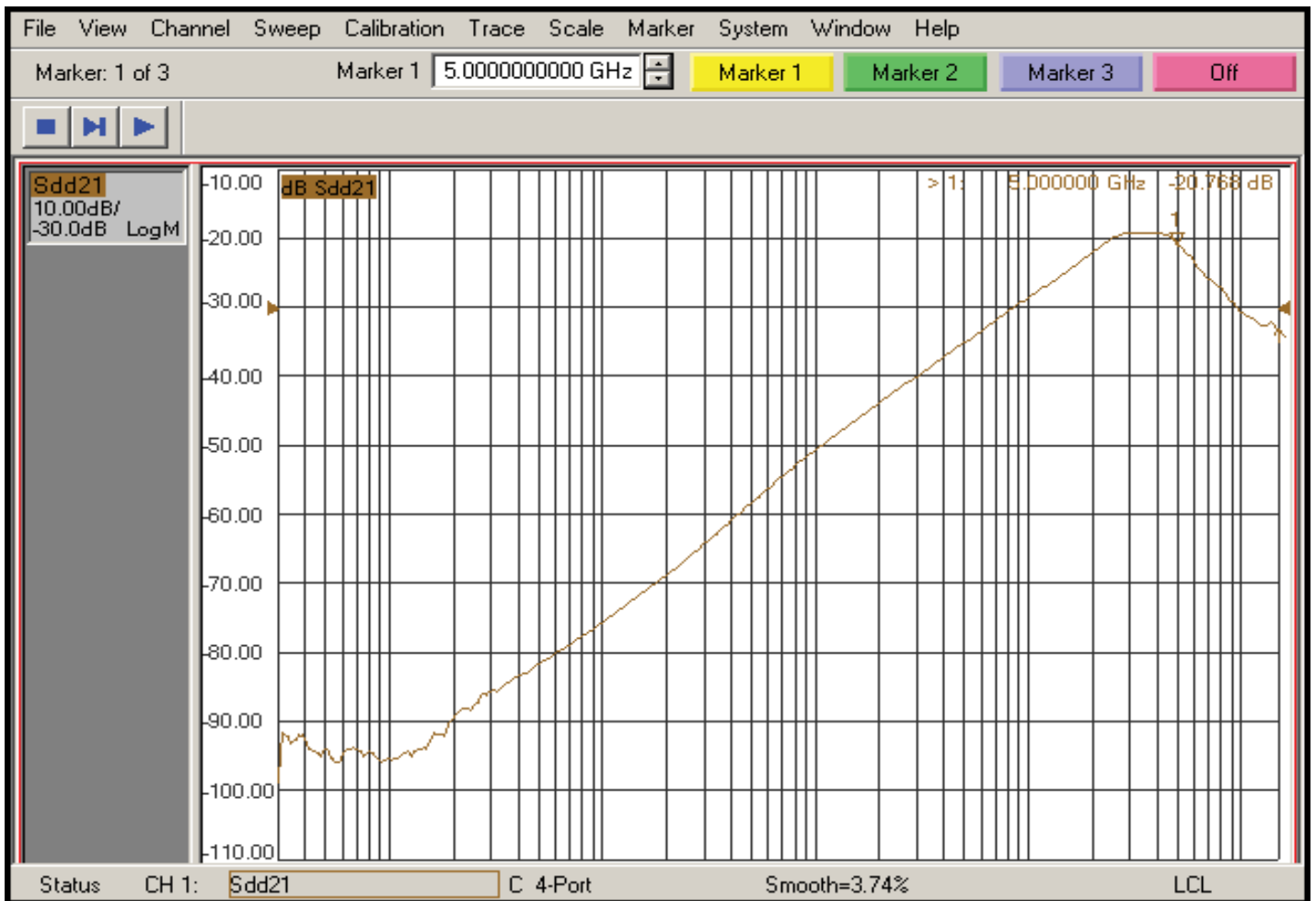
**Fig 2. Off-isolation setup**



**Fig 3. Differential Insertion Loss**

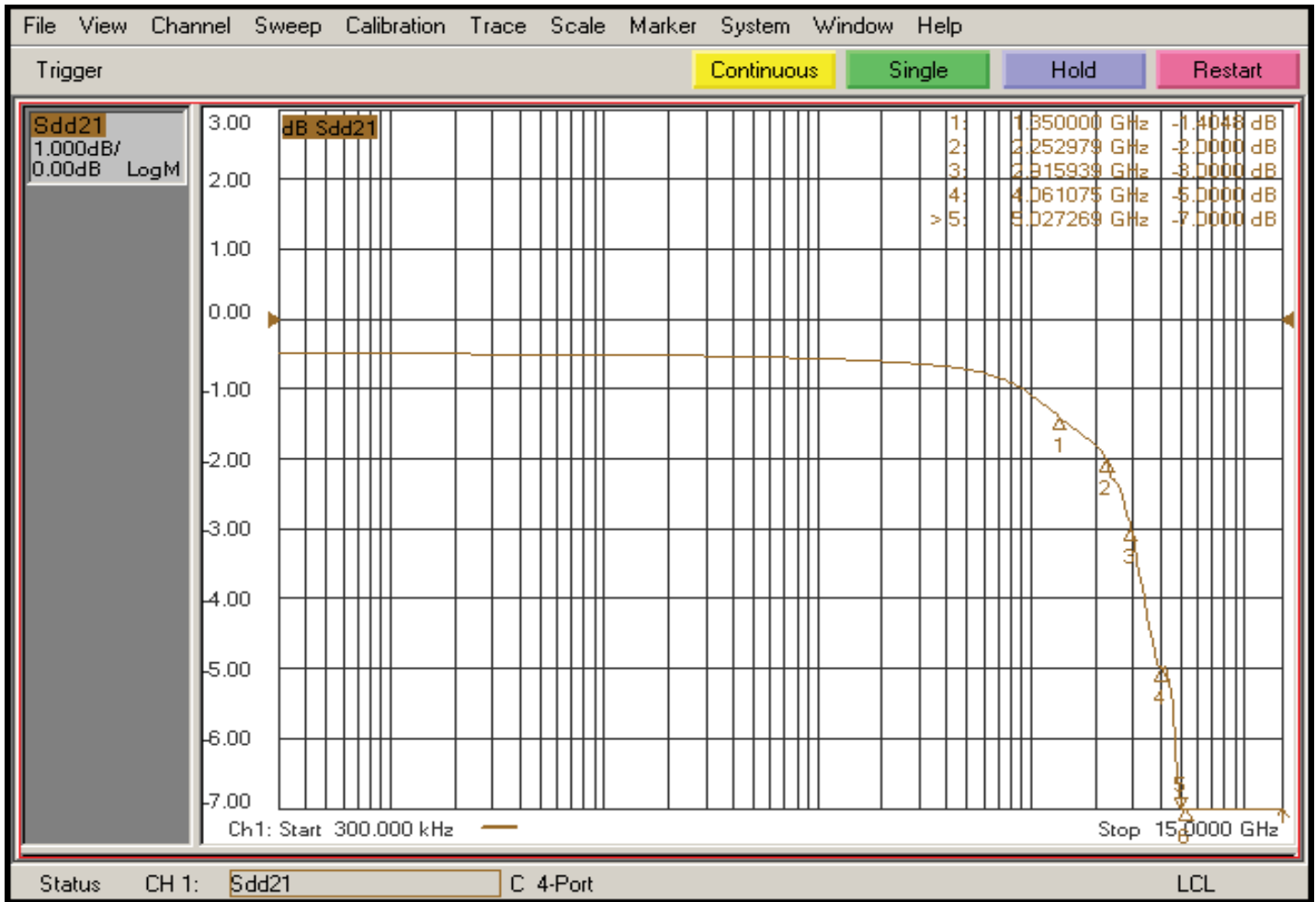


**Fig 4. Xtalk**

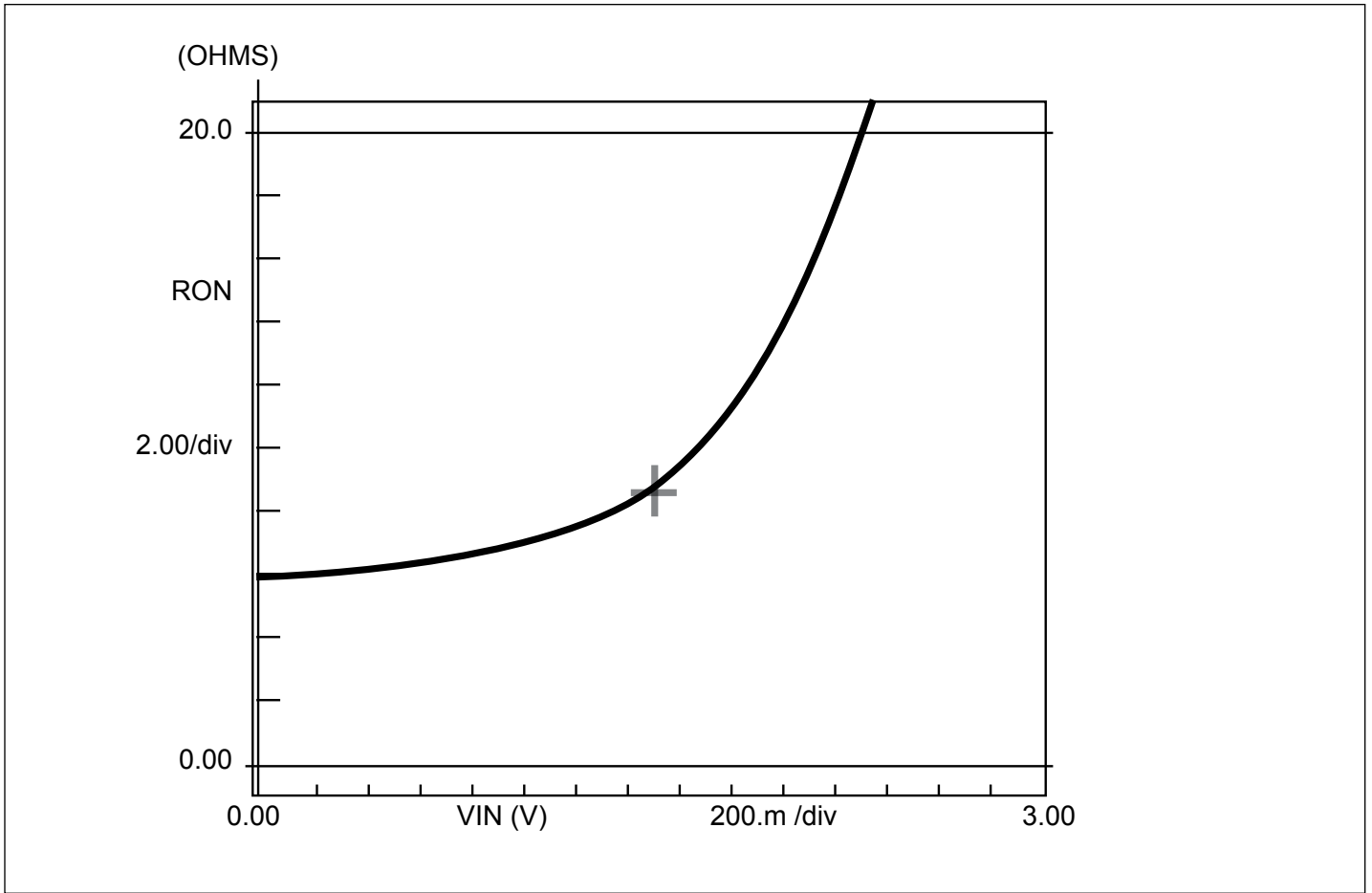


**Fig 5. Off Isolation**





**Fig 6. Insertion Loss**

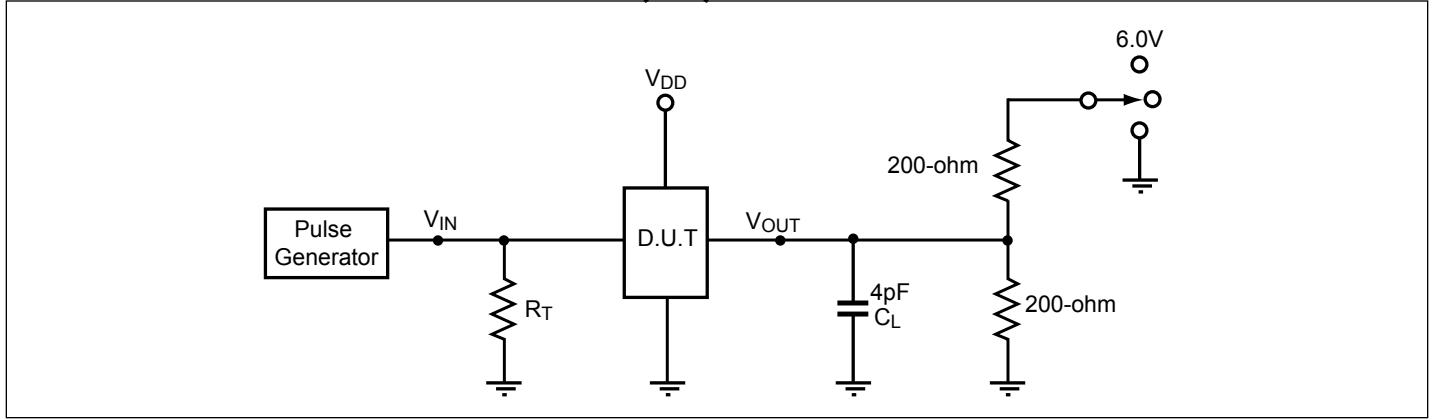


**Fig 7. Ron Curve for High Speed Signal Path Only (Dx±)**

**Switching Characteristics** ( $T_A = -40^\circ$  to  $+85^\circ\text{C}$ ,  $V_{DD} = 3.3\text{V} \pm 10\%$ )

Parameter	Description	Min.	Max.	Units
$t_{PZH}$ , $t_{PZL}$	Line Enable Time	0.5	15.0	ns
$t_{PHZ}$ , $t_{PLZ}$	Line Disable Time	0.5	15.0	
$T_{pd}$	Propagation delay (input pin to output pin)		200	ps
$t_{b-b}$	Bit-to-bit skew within the same differential pair		7	ps
$t_{ch-ch}$	Channel-to-channel skew		50	ps

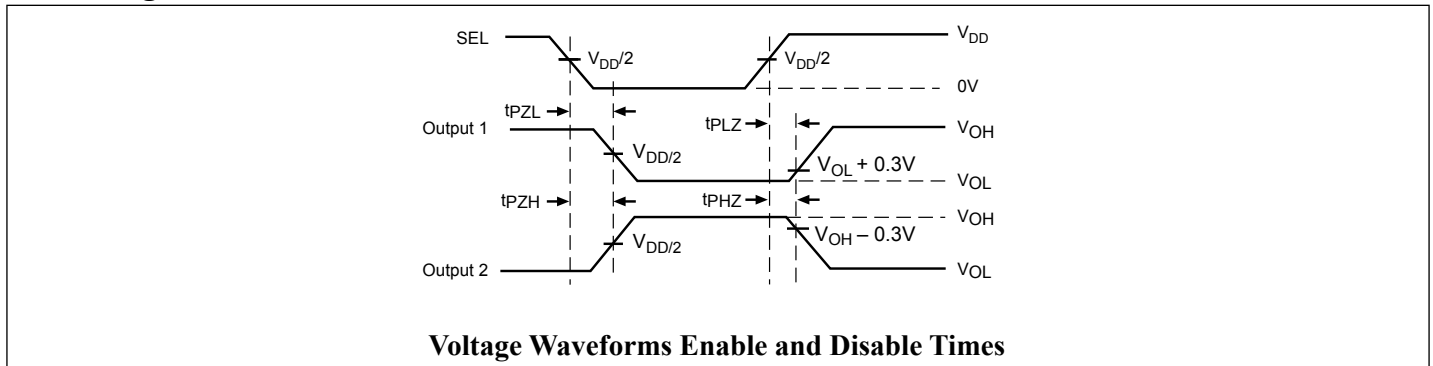
**Test Circuit for Electrical Characteristics(1-5)**



**Notes:**

- $C_L$  = Load capacitance: includes jig and probe capacitance.
- $R_T$  = Termination resistance: should be equal to  $Z_{OUT}$  of the Pulse Generator
- Output 1 is for an output with internal conditions such that the output is low except when disabled by the output control.  
output 2 is for an output with internal conditions such that the output is high except when disabled by the output control.
- All input impulses are supplied by generators having the following characteristics:  $PRR \leq \text{MHz}$ ,  $Z_O = 50\Omega$ ,  $t_R \leq 2.5\text{ns}$ ,  $t_F \leq 2.5\text{ns}$ .
- The outputs are measured one at a time with one transition per measurement.

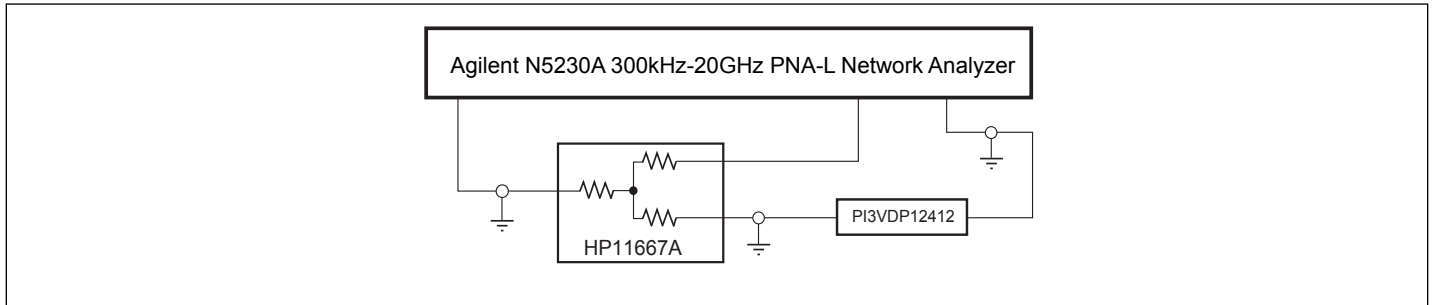
**Switching Waveforms**



**Switch Positions**

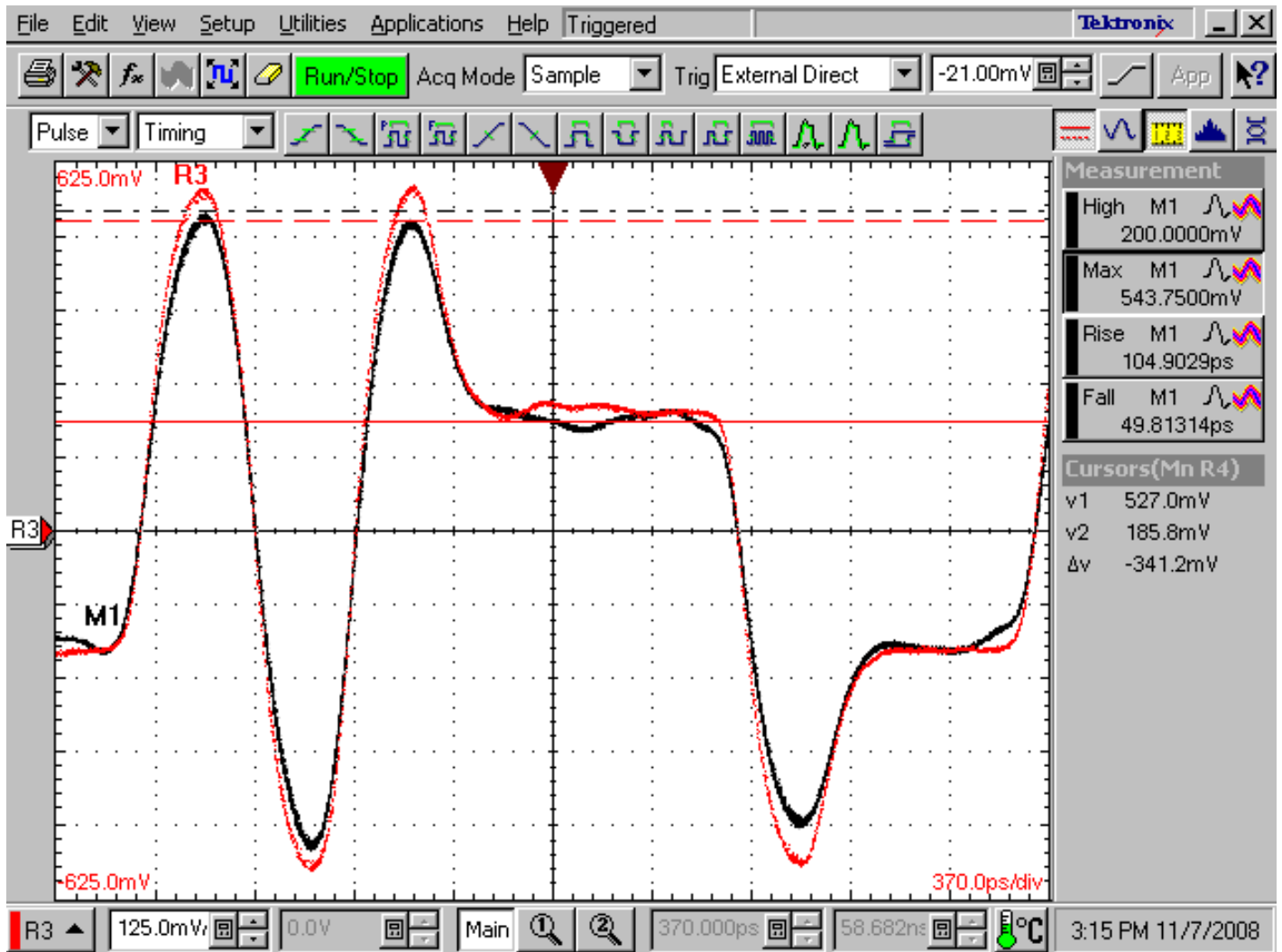
Test	Switch
$t_{PLZ}$ , $t_{PZL}$ (output on B-side)	6.0V
$t_{PHZ}$ , $t_{PZH}$ (output on B-side)	GND
Prop Delay	Open

**Test Circuit for Dynamic Electrical Characteristics**

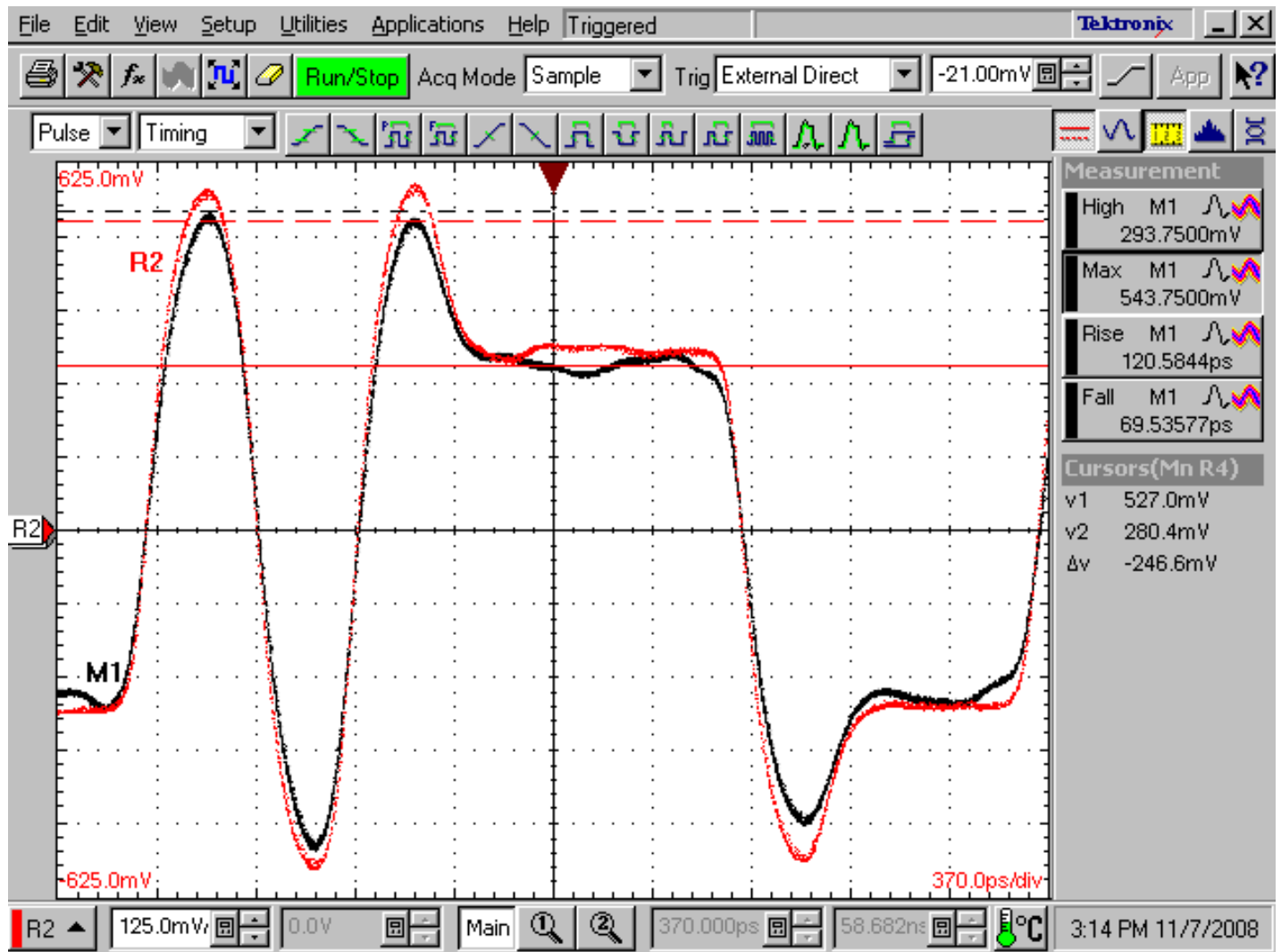


**Application Section - Pre-Emphasis Waveforms**

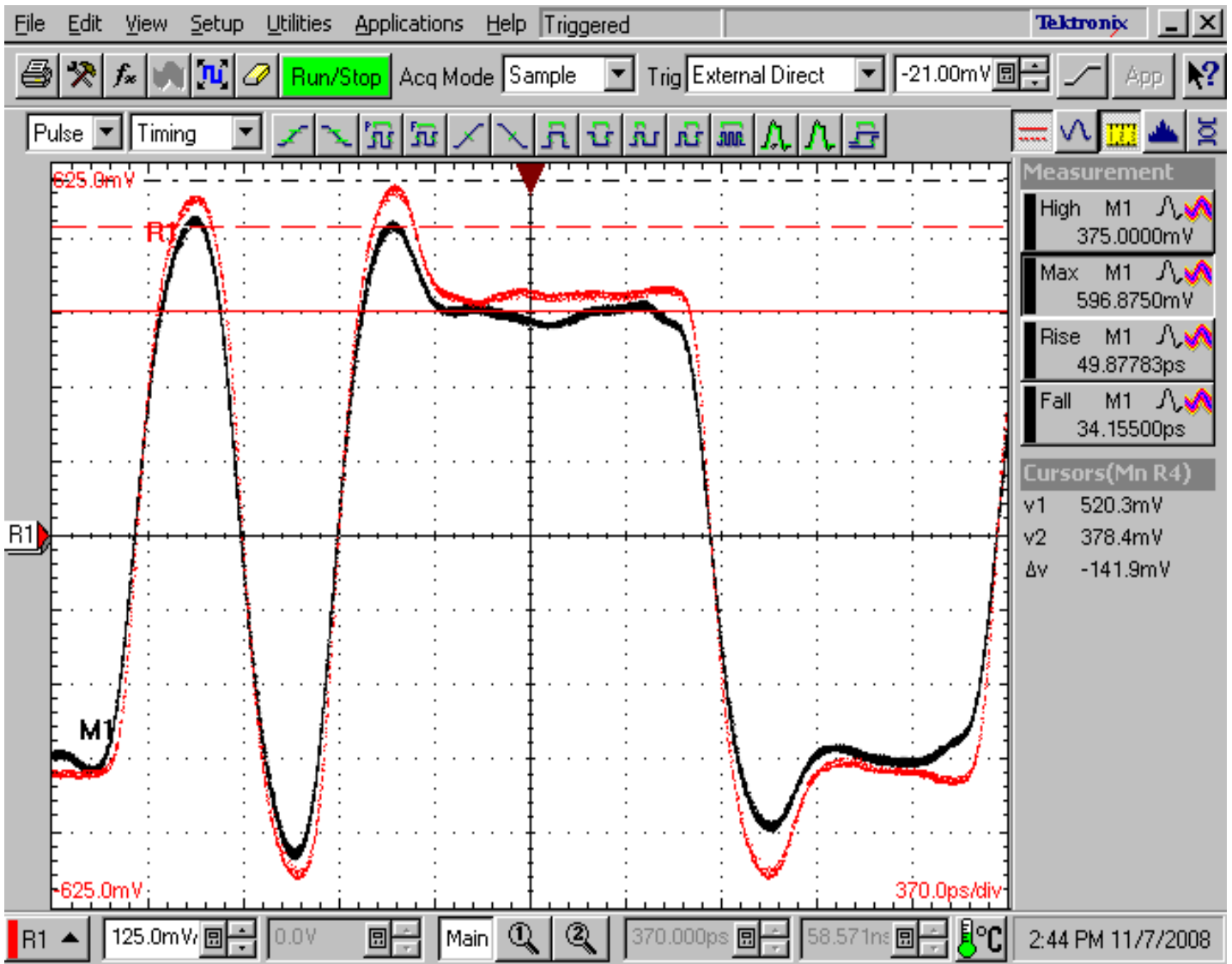
Input Pre-emphasis = 9.5dB; Red waveform is input of PI3VDP612-A & Black is output of PI3VDP612-A



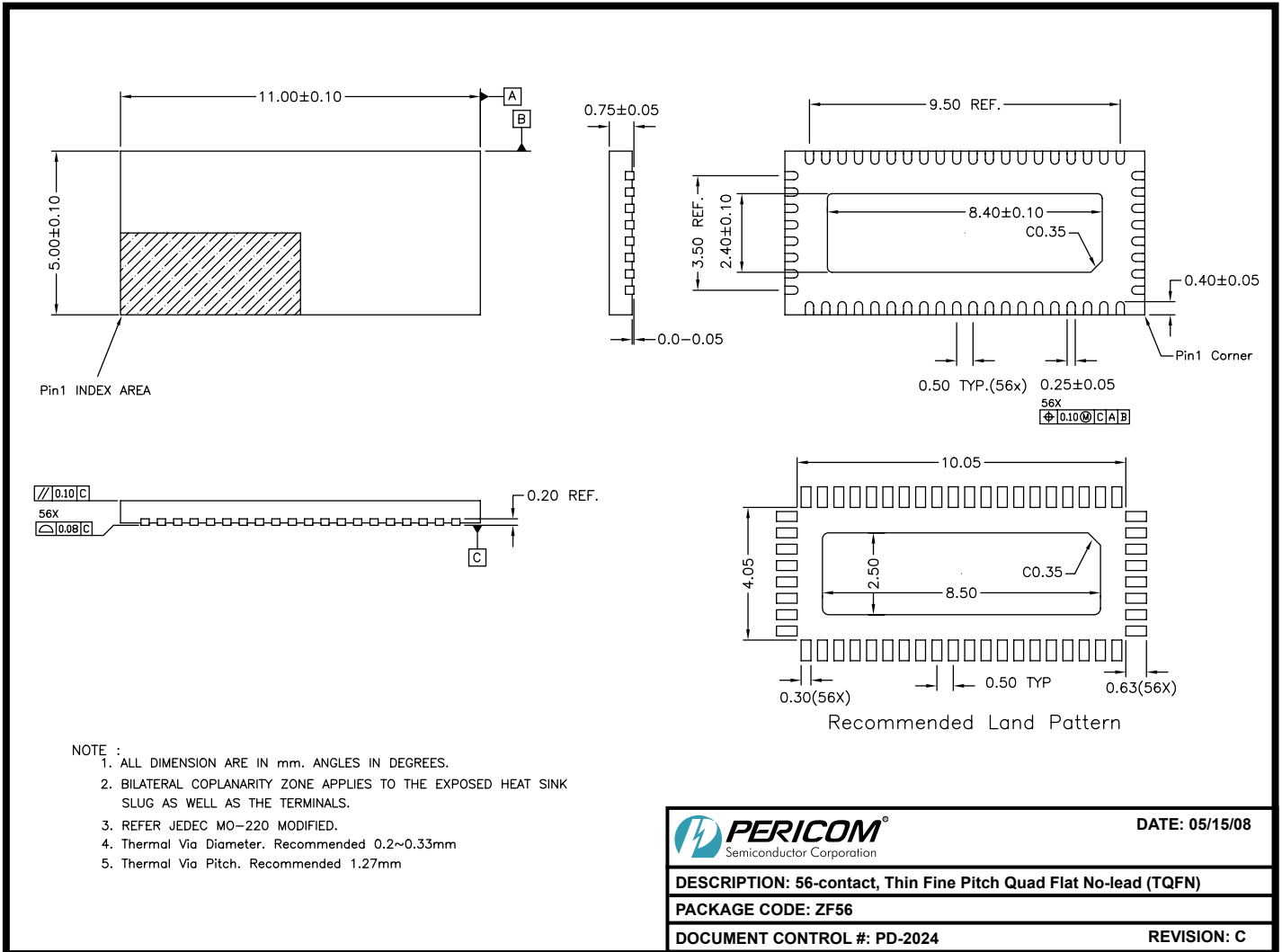
Input Pre-emphasis = 6dB; Red waveform is input of PI3VDP612-A and Black is output of PI3VDP612-A



Input Pre-emphasis = 3.5dB; Red waveform is input of PI3VDP612-A & Black is output of PI3VDP612-A



**Packaging Mechanical: 56-Contact TQFN (ZF)**

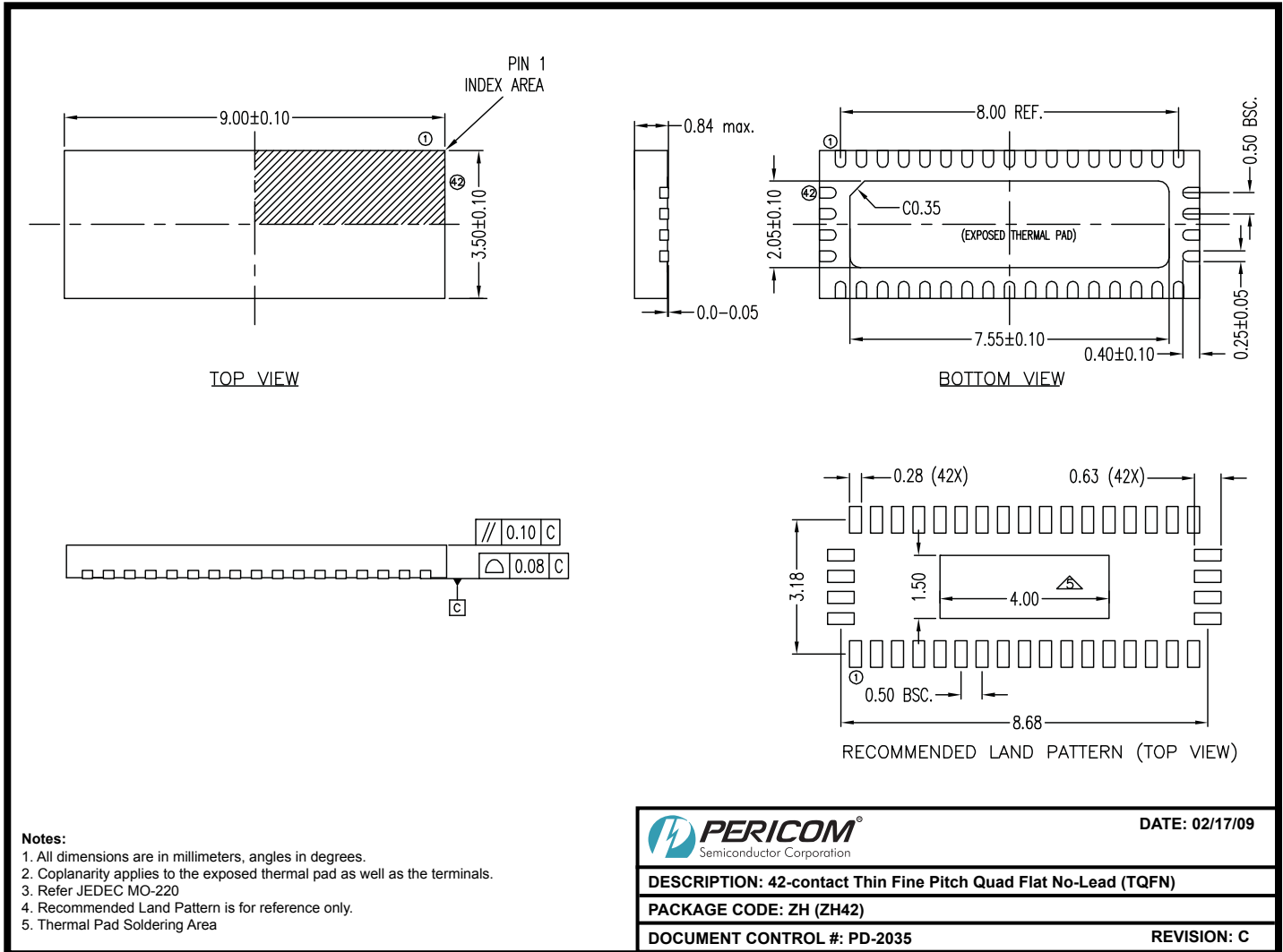


08-0208

**Note:**

- For latest package info, please check: <http://www.pericom.com/products/packaging/mechanicals.php>

**Packaging Mechanical: 42-Pin TQFN (ZH)**



09-0116

**Note:**

- For latest package info, please check: <http://www.pericom.com/products/packaging/mechanicals.php>

**Ordering Information**

Ordering Code	Package Code	Package Description
PI3VDP612-AZFE	ZF	Pb-free & Green, 56-contact TQFN
PI3VDP612-AZHE	ZH	Pb-free & Green, 42-contact TQFN

**Notes:**

- Thermal characteristics can be found on the company web site at [www.pericom.com/packaging/](http://www.pericom.com/packaging/)
- "E" denotes Pb-free and Green
- Adding an "X" at the end of the ordering code denotes tape and reel packaging



# Mouser Electronics

Authorized Distributor

Click to View Pricing, Inventory, Delivery & Lifecycle Information:

[Diodes Incorporated:](#)

[PI3VDP612-AZFEX](#) [PI3VDP612ZHEX](#) [PI3VDP612-AZHEX](#) [PI3VDP612ZHE](#) [PI3VDP612-AZFE](#) [PI3VDP612-AZHE](#)

Компания «Океан Электроники» предлагает заключение долгосрочных отношений при поставках импортных электронных компонентов на взаимовыгодных условиях!

Наши преимущества:

- Поставка оригинальных импортных электронных компонентов напрямую с производств Америки, Европы и Азии, а так же с крупнейших складов мира;
- Широкая линейка поставок активных и пассивных импортных электронных компонентов (более 30 млн. наименований);
- Поставка сложных, дефицитных, либо снятых с производства позиций;
- Оперативные сроки поставки под заказ (от 5 рабочих дней);
- Экспресс доставка в любую точку России;
- Помощь Конструкторского Отдела и консультации квалифицированных инженеров;
- Техническая поддержка проекта, помощь в подборе аналогов, поставка прототипов;
- Поставка электронных компонентов под контролем ВП;
- Система менеджмента качества сертифицирована по Международному стандарту ISO 9001;
- При необходимости вся продукция военного и аэрокосмического назначения проходит испытания и сертификацию в лаборатории (по согласованию с заказчиком);
- Поставка специализированных компонентов военного и аэрокосмического уровня качества (Xilinx, Altera, Analog Devices, Intersil, Interpoint, Microsemi, Actel, Aeroflex, Peregrine, VPT, Syfer, Eurofarad, Texas Instruments, MS Kennedy, Miteq, Cobham, E2V, MA-COM, Hittite, Mini-Circuits, General Dynamics и др.);

Компания «Океан Электроники» является официальным дистрибьютором и эксклюзивным представителем в России одного из крупнейших производителей разъемов военного и аэрокосмического назначения «JONHON», а так же официальным дистрибьютором и эксклюзивным представителем в России производителя высокотехнологичных и надежных решений для передачи СВЧ сигналов «FORSTAR».



## JONHON

«JONHON» (основан в 1970 г.)

Разъемы специального, военного и аэрокосмического назначения:

(Применяются в военной, авиационной, аэрокосмической, морской, железнодорожной, горно- и нефтедобывающей отраслях промышленности)

«FORSTAR» (основан в 1998 г.)

ВЧ соединители, коаксиальные кабели, кабельные сборки и микроволновые компоненты:

(Применяются в телекоммуникациях гражданского и специального назначения, в средствах связи, РЛС, а так же военной, авиационной и аэрокосмической отраслях промышленности).



Телефон: 8 (812) 309-75-97 (многоканальный)

Факс: 8 (812) 320-03-32

Электронная почта: [ocean@oceanchips.ru](mailto:ocean@oceanchips.ru)

Web: <http://oceanchips.ru/>

Адрес: 198099, г. Санкт-Петербург, ул. Калинина, д. 2, корп. 4, лит. А